

FITTING INSTRUCTIONS

FOR SIDE SWING WINDOW 90° WITH FRICTION IPA NO. 21193

EXAMPLE WOOD PROFILE

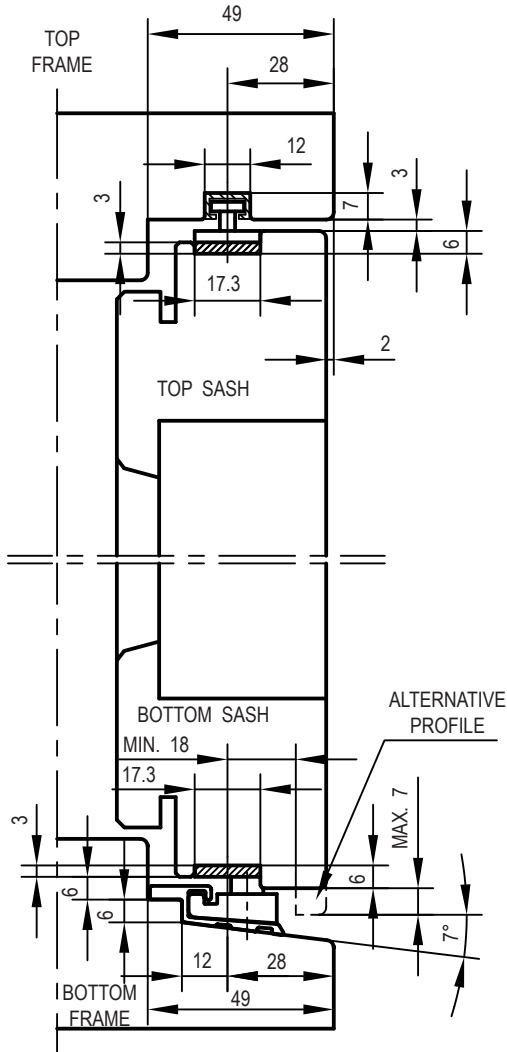

FIG. 1
VERTICAL PLAN

SIDE FRAME AND SIDE SASH MUST HAVE THE SAME PROFILE AS TOP FRAME AND TOP SASH.

FITTING:

1. FIT THE ALUMINIUM RAILS INTO TOP AND BOTTOM FRAME SO THAT THE BOTTOM RAIL IS PLACED AGAINST THE FRAME ON THE HINGE SIDE. FASTEN THE SCREWS (FIGURE 1 AND 2).
2. INSERT SASH INTO POSITION OF THE STEERING KNUCKLE ARMS - GUIDED BY THE SASH GROOVE. FASTEN THE SCREWS.
3. NOW THE FRICTION CAN BE ADJUSTED ON THE TOP FITTING.

MAINTENANCE:

DO NOT PAINT THE ALUMINIUM RAILS.
 WHEN FITTING - LUBRICATE THE MOVABLE METAL PARTS OF THE MECHANISM WHILE ACTIVATING REPEATEDLY. HEREAFTER LUBRICATE MINIMUM TWICE A YEAR.

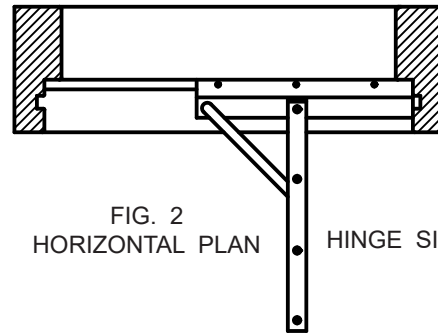

FIG. 2
HORIZONTAL PLAN HINGE SIDE

FITTING SHOWN ON BOTTOM CILL
 RIGHT HAND ILLUSTRATION

IPA NO.	21193
MAX. WEIGHT OF SASH KG	40
MIN. WIDTH OF SASH	320
MAX. WIDTH OF SASH	820
USE SCREW NO.	4.0

FIG. 3

REG. TALL WINDOWS:

FOR TALL AND NARROW SASHES PLEASE NOTE THAT THE TOP AND BOTTOM SLIDING ELEMENTS MAY NOT MOVE EXACTLY ALIKE, BECAUSE OF THE DISTANCE BETWEEN THE TWO ELEMENTS. THIS MAY MAKE THE MOVE- MENT OF THE SASH A LITTLE MORE DIFFICULT. EVT. USE BOTH HANDS.

IMPORTANT: WHEN FITTING/MOUNTING THE WINDOW IT IS NECESSARY THAT THE TOP AND BOTTOM FRAMES ARE STRAIGHT. THIS IS IMPERATIVE FOR THE SLIDES TO TRAVEL FREELY IN THEIR ALUMINIUM RAILS.