

## FITTING INSTRUCTIONS

FOR ADJUSTABLE CANOPY STAY WITH ADJUSTABLE FRICTION IPA NO. 62888

REHAU NORDIC DESIGN PLUS:

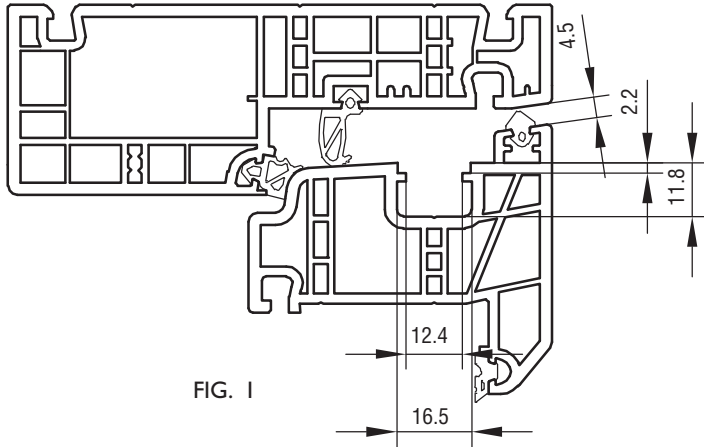

FIG. 1

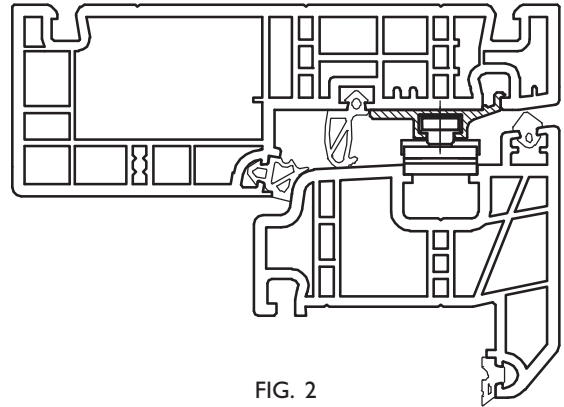

FIG. 2

IPA NO.	62888
MAX. SASH WEIGHT KG	70
MAX. FRAME HEIGHT MM	1400
USE SCREW NO.	4.0

### FITTING:

1. CLOSE THE FITTING AND PLACE IT IN THE GROOVE OF THE SIDE FRAME. PLACE THE FITTING AGAINST THE TOP FRAME. PLACE AND FASTEN THE SCREW IN THE BOTTOM HOLE AND THE HOLE IN THE SIDE PART OF THE ALU-RAIL. OPEN THE FITTING AND FASTEN THE REMAINING SCREWS.
2. PUSH THE SASH INTO ITS PLACE BY INSERTING IT BETWEEN THE FITTINGS, GUIDED BY THE GROOVES IN THE SASH, TILL THE SASH HITS THE STOPS OF THE FITTING. FASTEN THE FITTING STARTING WITH THE SCREW IN THE STOP BRACKET. FINALLY FASTEN THE STOP IN THE ALU-RAIL.
3. NOW THE FRICTION MAY BE ADJUSTED BY MEANS OF THE SCREWS IN THE ALUMINIUM RAILS. BEFORE ADJUSTMENT, PRESS THE SLIDING PART DOWN TO THE STOPS. THE BEST RESULT FOR THE WINDOW MOVEMENT IS ACHIEVED BY EQUAL FRICTION AT BOTH SIDES AND TO SECURE THIS THE SCREWS MUST NEVER BE FASTENED MORE THAN JUST ENOUGH TO HOLD THE WINDOW IN OPEN POSITION. PLEASE NOTE THAT WITH A SMALL WINDOW OPENING, THE FRICTION IS NOT INFLUENCED BY TIGHTENING THE SCREWS HARDER. TO ENSURE THE WINDOW IN STAYING OPENED WITH A SMALL WINDOW OPENING, WE RECOMMEND MOUNTING A SAFETY CATCH.
4. THE SASH CAN BE ADJUSTED  $\pm 1.5$  MM UP OR DOWN. ADJUST BY USING A TORX-20 KEY TO TURN THE ECCENTRIC SCREW. BY DELIVERY THE MARK ON THE ECCENTRIC SCREW IS IN A VERTICAL POSITION INDICATING THE 0-POSITION. WHEN THE MARK IS IN HORIZONTAL POSITION IN EITHER TOP OR BOTTOM, THE FITTING IS ADJUSTED TO IT'S MAX OF  $\pm 1.5$  MM.

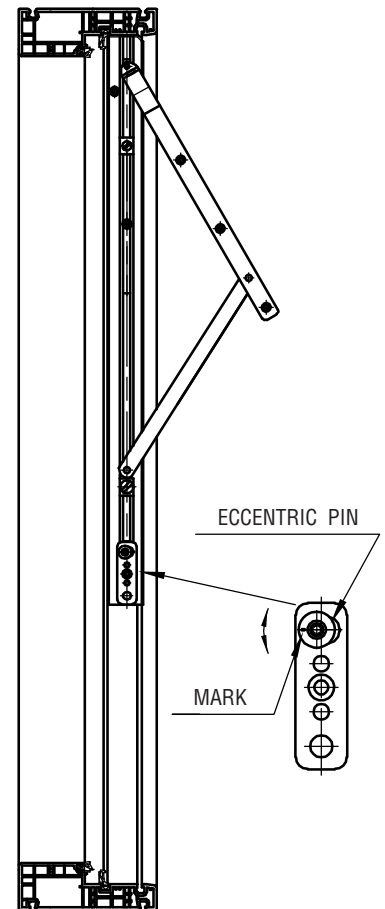

FIG. 3

### MAINTENANCE:

THE FITTINGS ARE NOT TO BE PAINTED. TEST THE OPERATION FROM TIME TO TIME. WHEN FITTING - LUBRICATE THE PIVOT/MOVABLE METAL PARTS OF THE MECHANISM WHILE ACTIVATING REPEATEDLY. HEREAFTER LUBRICATE MINIMUM TWICE A YEAR. DO NOT LUBRICATE THE ALUMINIUM RAILS.