

FITTING INSTRUCTIONS

FOR FRICTION STAY FOR DOORS IPA NO. 63511

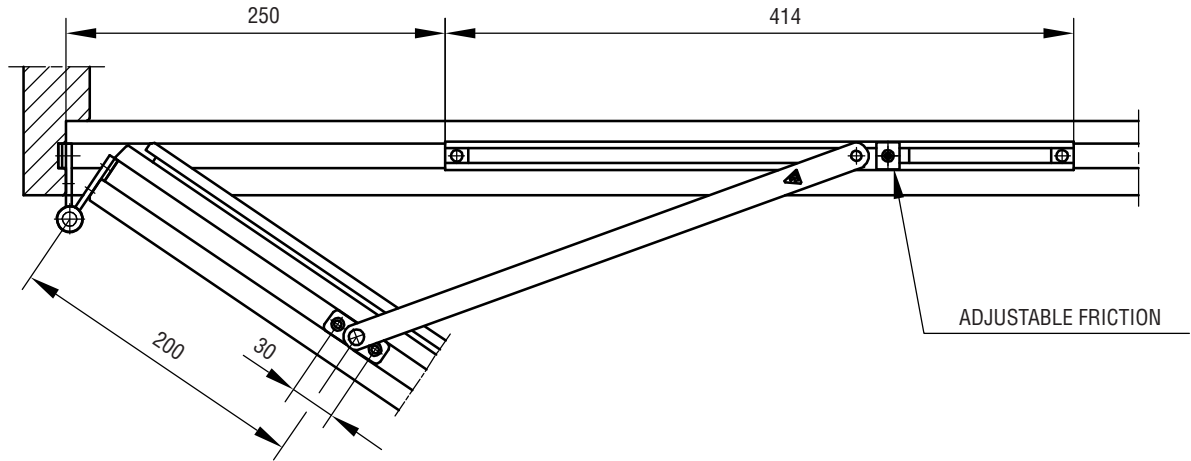

FIG. 1

EXAMPLE WOOD PROFILE

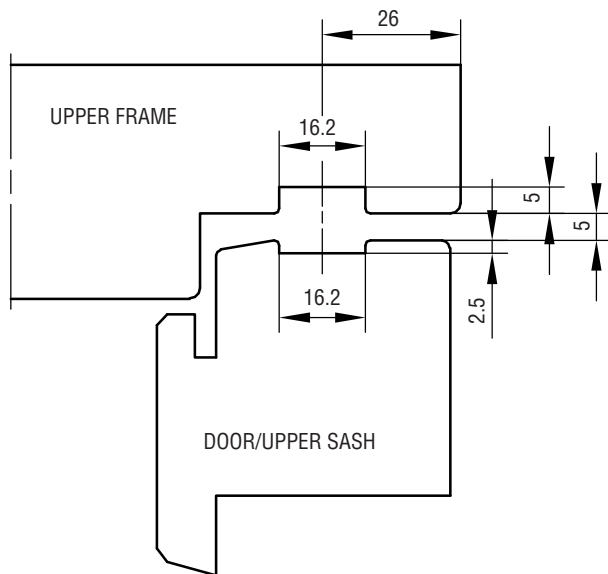

FIG. 2

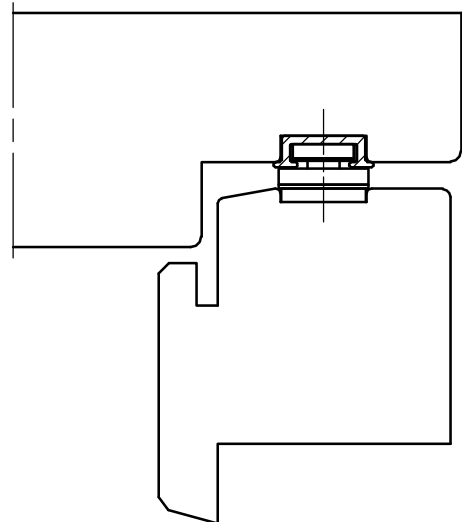

FIG. 3

USE SCREW NO. 4.0

MAINTENANCE:

THE FITTING ARE NOT TO BE PAINTED. TEST THE OPERATION FROM TIME TO TIME. WHEN MOUNTING - LUBRICATE THE PIVOT/MOVABLE METAL PARTS OF THE MECHANISM WHILE ACTIVATING REPEATEDLY. HEREAFTER LUBRICATE MINIMUM TWICE A YEAR. DO NOT LUBRICATE THE ALUMINIUM RAILS.