

## FITTING INSTRUCTIONS

### ROLLER ESPAGNOLETTE BOLTS IPA NO.s 23151-60 & 23161-70

IPA NO.	L MM	C MM	A MM BACKSET	B MM
23151	300	195	25	34
23152	400	295		
23153	500	395		
23154	600	495		
23156	800	695		
23158	1000	895		
23160	1200	1095	28	37
23161	300	195		
23162	400	295		
23163	500	395		
23164	600	495		
23166	800	695		
23168	1000	895		
23170	1200	1095		

FIG. 1

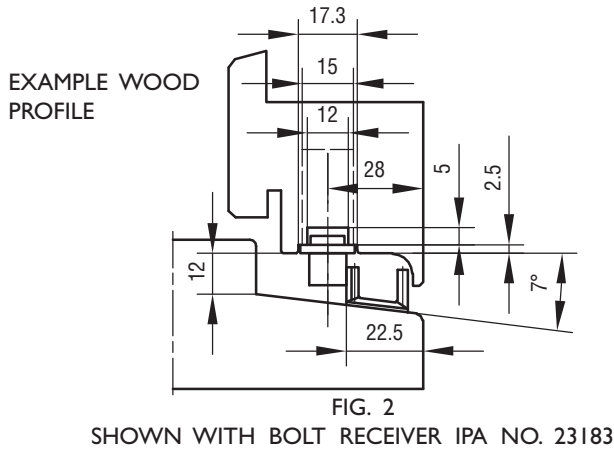

FIG. 2

SHOWN WITH BOLT RECEIVER IPA NO. 23183

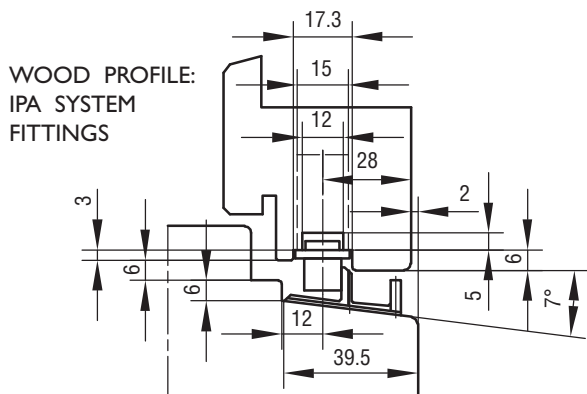

FIG. 3

SHOWN WITH IPA SYSTEM BOLT RECEIVER IPA NO. 23185

USE SCREW NO. 4.0

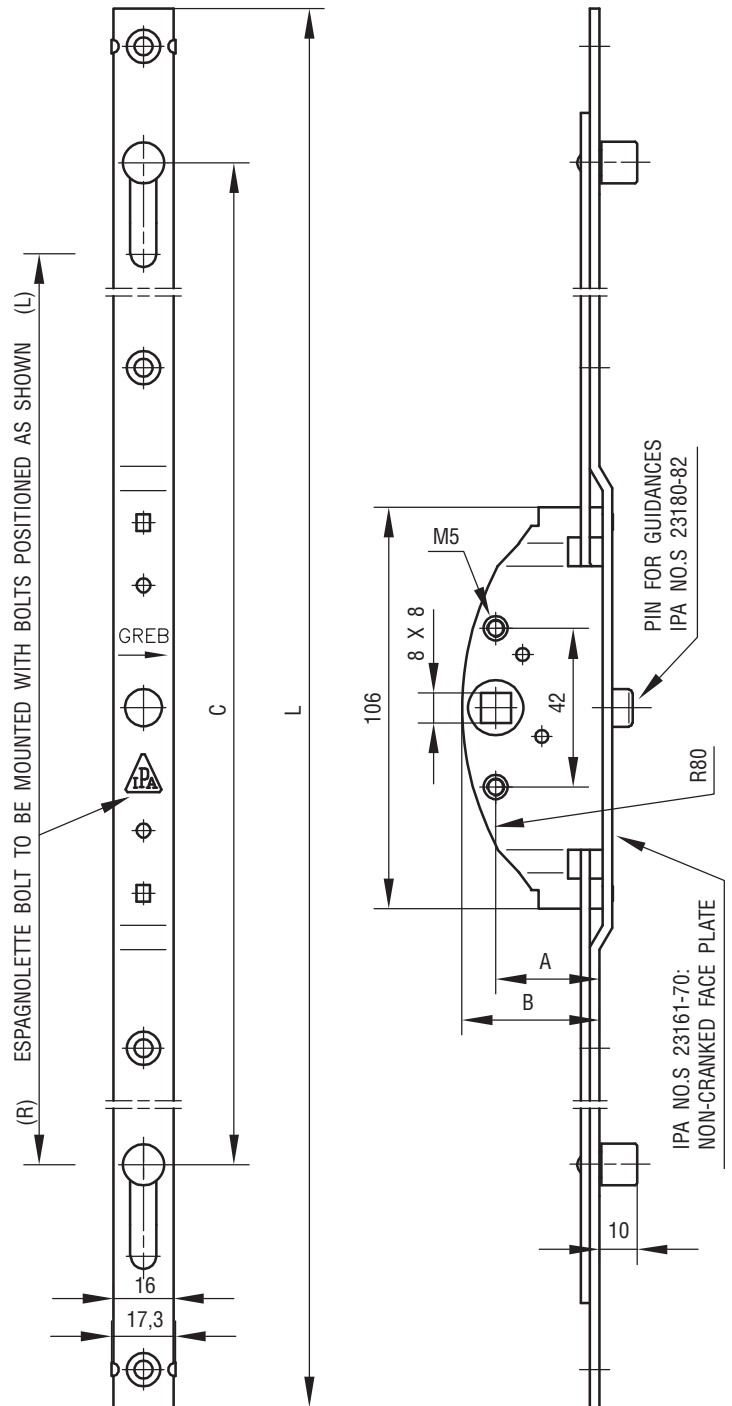

FIG. 4

**MAINTENANCE:**

WHEN FITTING - LUBRICATE THE MOVABLE METAL PARTS OF THE MECHANISM WHILE ACTIVATING REPEATEDLY. HEREAFTER LUBRICATE MINIMUM TWICE A YEAR.