

FITTING INSTRUCTIONS

CANOPY STAYS WITH FRICTION IPA NO.s 62570-75

EXAMPLE WOOD PROFILE:

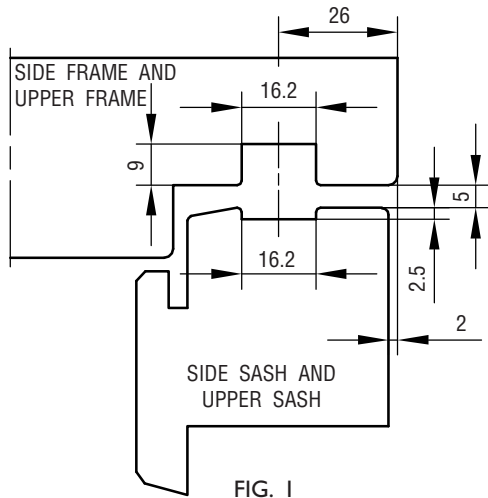

FIG. 1

HORIZONTAL PLANE

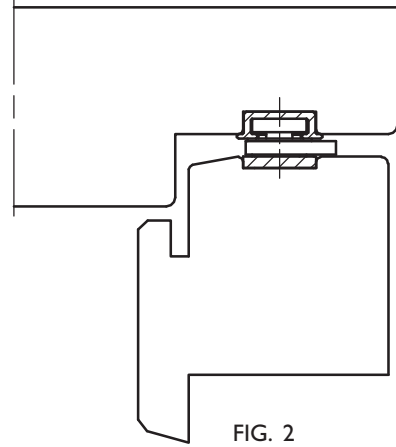

FIG. 2

IPA NO.	62570	62573	62574	62575
MAX. SASH WEIGHT KG	40	50	70	20
MAX. INSIDE FRAME HEIGHT MM	844	1344	1544	310
USE SCREW NO.	4.0	4.0	4.0	4.0

ESPECIALLY FOR IPA NO. 62573 OG 62574: THE SCREW IN THE TOP OF THE FRICTION ELEMENT IS ONLY TO ENSURE THAT THE GLIDING ELEMENT BELOW MOVES CORRECTLY IN THE ALUMINIUM RAIL. THEREFORE THIS SCREW MUST NOT BE ADJUSTED.

FITTING:

- CLOSE THE FITTING AND PLACE IT IN THE GROOVE OF THE SIDE FRAME. PLACE THE FITTING AGAINST THE TOP FRAME. PLACE AND FASTEN THE SCREW IN THE BOTTOM HOLE OF THE FITTING.
 - 62573: FASTEN THE STOP PLATE THROUGH THE UPPER SCREW HOLE IN THE STOP PLATE AND THROUGH THE UPPER SCREW HOLE IN THE ALURAIL. THIS ENABLES MAX. FIRE ESCAPE OPENING. USE LOWER SCREW HOLE IN STOP PLATE TO ACHIEVE A MAX., SASH LOAD OF 60 KGS. IF LOWER SCREW HOLE IS USED THE FIRE ESCAPE OPENING WILL BE REDUCED.
 - 62574: ALWAYS USE THE UPPER SCREW HOLE IN THE ALURAIL FOR FASTENING THE STOP PLATE. USE THE UPPER SCREW HOLE IN STOP PLATE FOR MAX. FIRE ESCAPE OPENING. USE THE MIDDLE SCREW HOLE IN THE STOP PLATE TO ACHIEVE A MAX. SASH LOAD OF 85 KGS. USE THE LOWER SCREW HOLE IN THE STOP PLATE TO ACHIEVE A MAX. SASH LOAD OF 100 KGS. IF MIDDLE OR LOWER SCREW HOLES IN STOP PLATE ARE USED THE FIRE ESCAPE OPENING WILL BE REDUCED.
- PUSH THE SASH INTO ITS PLACE BY INSERTING IT BETWEEN THE HINGE ARMS, GUIDED BY THE GROOVES IN THE SASH, UNTIL THE SASH HITS THE STOPS OF THE FITTING. THESE STOPS WILL GUARANTEE A 5 MM GAB BETWEEN FRAME AND SASH. FASTEN THE FITTING STARTING WITH THE SCREW IN THE STOP BRACKET (IPA NO. 62570-74).
- NOW THE FRICTION MAY BE ADJUSTED BY MEANS OF THE SCREWS IN THE SLIDES. BEFORE ADJUSTMENT, PRESS THE SLIDING PART DOWN TO THE STOPS. THE BEST RESULT FOR THE WINDOW MOVEMENT IS ACHIEVED BY EQUAL FRICTION AT BOTH SIDES AND TO ENSURE THIS THE SCREWS MUST NEVER BE FASTENED MORE THAN JUST ENOUGH TO HOLD THE WINDOW IN OPEN POSITION. PLEASE NOTE THAT WITH A SMALL WINDOW OPENING, THE FRICTION IS NOT INFLUENCED BY TIGHTENING THE SCREWS HARDER. TO ENSURE THE WINDOW IN STAYING OPENED WITH A SMALL WINDOW OPENING, WE RECOMMEND MOUNTING A SAFETY CATCH.

OBS! RE. IPA NO. 62573:

FOR BIG WINDOWS (>1200 MM) WITH 3-LAYER GLASS AND NO REQUIREMENTS FOR EGRESS OPENINGS THE USE OF IPA NO. 62574 IS RECOMMENDED, AS THE VENTILATION POSITION OTHERWISE MAY BE DIFFICULT TO ACHIEVE BECAUSE OF THE OPENING GEOMETRY OF THE GEARS.

MAINTENANCE:

THE FITTINGS ARE NOT TO BE PAINTED. TEST THE OPERATION FROM TIME TO TIME. WHEN FITTING - LUBRICATE THE PIVOT/MOVABLE METAL PARTS OF THE MECHANISM WHILE ACTIVATING REPEATEDLY. HEREAFTER LUBRICATE MINIMUM TWICE A YEAR. DO NOT LUBRICATE THE ALUMINIUM RAILS.

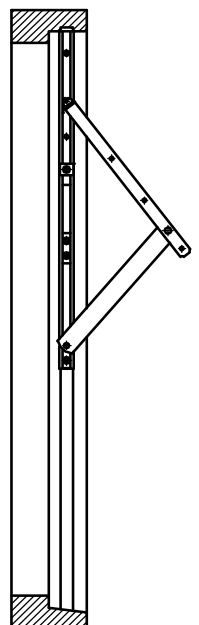

FIG. 3