

## FITTING INSTRUCTIONS

FOR FRICTION STAY FOR WINDOWS IPA NO. 62927

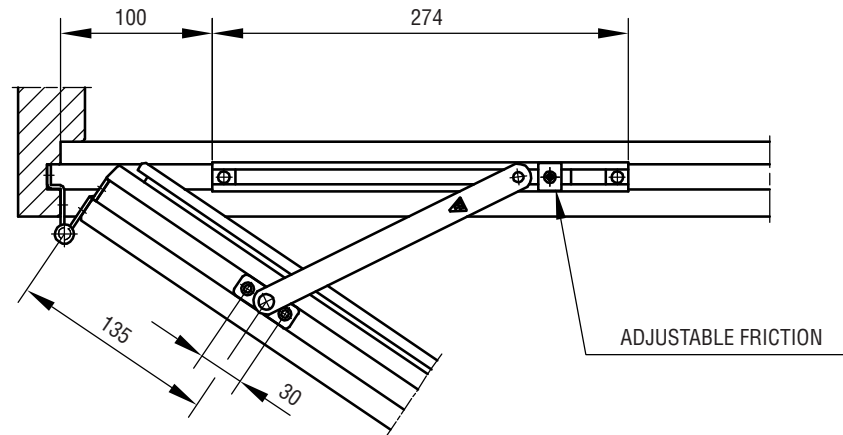

FIG. 1

EXAMPLE WOOD PROFILE

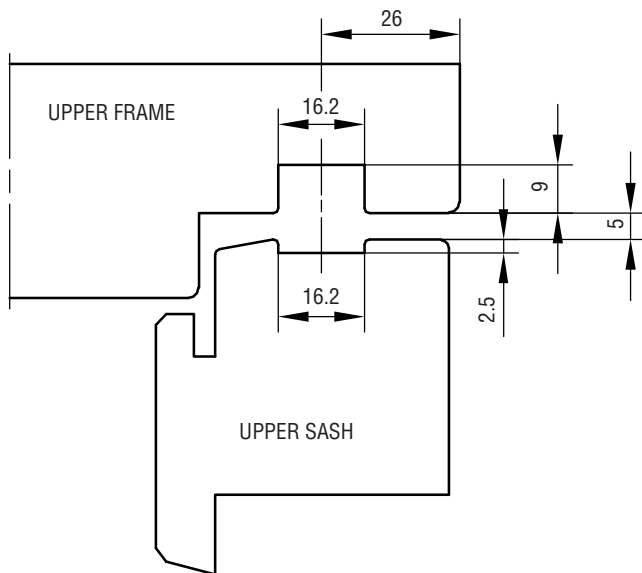

FIG. 2

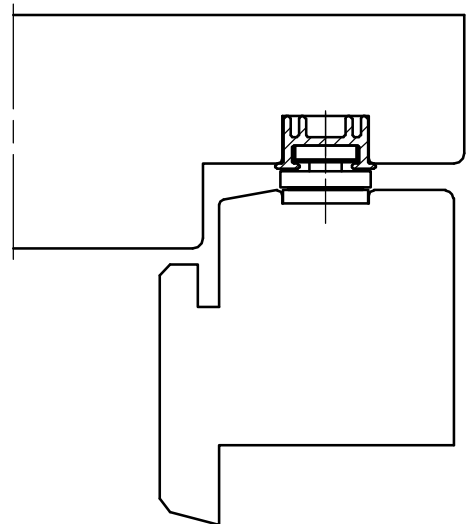

FIG. 3

USE SCREW NO. 4.0

**MAINTENANCE:**

THE FITTING ARE NOT TO BE PAINTED. TEST THE OPERATION FROM TIME TO TIME. WHEN MOUNTING - LUBRICATE THE PIVOT/MOVABLE METAL PARTS OF THE MECHANISM WHILE ACTIVATING REPEATEDLY. HEREAFTER LUBRICATE MINIMUM TWICE A YEAR. DO NOT LUBRICATE THE ALUMINIUM RAILS.